

Installation Guide

CIES



WHERE ARE WE

Calle Dinámica N°1, PoL. Ind. Santa Rita
08755 Castellbisbal, Barcelona SPAIN



CALL US

Ph +34 918 315 425
Fax +34 937 720 018



DOWNLOAD



faro@lorefar.com
www.faro.es



FOLLOW US



CONGRATULATIONS

> **ESPAÑOL** Felicidades por la compra de su nuevo ventilador Faro Barcelona que le proporcionará, diseño, calidad y confort durante muchos años. Estamos orgullosos de nuestro trabajo y apreciamos la oportunidad de suministrarle uno de los mejores ventiladores de techo disponibles. ¡Toca empezar a disfrutar de su ventilador de techo Faro Barcelona!

> **CATALÀ** Felicitats per la compra del seu nou ventilador Faro Barcelona que li proporcionarà, disseny, qualitat i confort durant molts anys. Estem orgullosos del nostre treball i apreciem l'oportunitat de subministrar-li un dels millors ventiladors de sostre disponibles. Comenci a gaudir del seu ventilador de sostre Faro Barcelona!

> **ENGLISH** Congratulations on the purchase of your new Faro Barcelona fan that will provide you, design, quality and comfort for many years. We are proud of our work and appreciate the opportunity to provide one of the best ceiling fans available. It's time to start enjoying your Faro Barcelona ceiling fan!

> **FRANÇAIS** Félicitations pour l'achat de votre nouveau ventilateur Faro Barcelona qui vous apportera design, qualité et confort pendant de nombreuses années. Nous sommes fiers de notre travail et apprécions l'oportunité de fournir l'un des meilleurs ventilateurs de plafond disponibles. Il est temps de

commencer à profiter de votre ventilateur de plafond Faro Barcelona!

> **ITALIANO** Congratulazioni per aver acquistato un ventilatore Faro Barcelona che le garantirà design, qualità e comfort per molto tempo.

Siamo orgogliosi del nostro lavoro e apprezziamo molto che ci abbia dato l'oportunità di fornirle uno dei migliori ventilatori da soffitto disponibili nel mercato. Cominci ad utilizzare il suo nuovo ventilatore da soffitto Faro Barcelona!

> **PORTUGÊS** Parabéns pela compra do seu novo ventilador de Faro Barcelona que lhe proporcionará design, qualidade e conforto por muitos anos. Estamos orgulhosos do nosso trabalho e apreciamos a oportunidade de fornecer um dos melhores ventiladores de teto disponíveis. É hora de começar a desfrutar do seu ventilador de teto Faro Barcelona!

> **DEUTSCH** Herzlichen Glückwunsch zum Kauf Ihres neuen Faro Barcelona Ventilators, der Ihnen Design, Qualität und Komfort für viele Jahre bieten wird. Wir sind stolz auf unsere Arbeit und schätzen die Möglichkeit, Ihnen einen der besten Deckenventilatoren zu liefern. Es ist an der Zeit, Ihren Faro Barcelona Deckenventilator zu genießen!

> **NEDERLANDS** Gefeliciteerd met de aankoop van uw nieuwe Faro Barcelona ventilator. Deze zal u kwaliteit en confort bieden voor vele jaren. Wij zijn trots op ons werk, en waarderen de mogelijkheid om u een van de beste

beschikbare plafondventilatoren te leveren. Geniet van uw nieuwe Faro Barcelona plafondventilator!

> **ΕΛΛΗΝΙΚΗ** Συγχαρητήρια για την αγορά του νέου σας ανεμιστήρα Faro Barcelona που θα σας προσφέρει ηχάζιν, ποιότητα και άνεση για πολλά χρόνια. Είμαστε υπερήφανοι για την δουλειά μας και εκτιμούμε την ευκαιρία να σας προσφέρουμε έναν από τους καλύτερους ανεμιστήρες οροφής της αγοράς. Ήρθε η ώρα να απολαύσετε τον ανεμιστήρα οροφής Faro Barcelona!

> **РУССКИЙ** Поздравляем вас с приобретением вентилятора Faro Barcelona нового поколения, который будет радовать вас своим дизайном, качеством и комфортом в течение многих лет. Мы гордимся нашей работой и ценим возможность предоставить вам один из лучших потолочных вентиляторов. Пришло время начать наслаждаться потолочным вентилятором Faro Barcelona!

> **ČESKY** Gratulujeme vám k zakoupení vašeho nového ventilátoru Faro Barcelona, který vám poskytne design, kvalitu a komfort po mnoho let. Jsme hrdí na naši práci a vážíme si příležitosti poskytnout vám jeden z nejlepších stropních ventilátorů na trhu. Je načase začít si užívat váš stropní ventilátor Faro Barcelona!

> **POLSKI** Gratulujemy zakupu nowego wentylatora Faro Barcelona, który zapewni Ci design, jakość i komfort

przez wiele lat. Jesteśmy dumni z naszej pracy i doceniamy możliwość zaferowania jednego z najlepszych dostępnych wentylatorów sufitowych. Czas zacząć cieszyć się swoim wentylatorem Faro Barcelona!

> **БЪЛГАРСКИ** Поздравления за закупуването на новия вентилатор от Faro Barcelona, който ще ви осигури дизайн, качество и удобство в продължение на много години. Гордеем се с нашата продукция и оценяваме възможността да ви предоставим един от най-добрите таванни вентилатори. Време е да започнете да се наслаждавате на таванния вентилатор на Faro Barcelona!

>> **SLOVENČINA** Blahoželáme k nákupu vášho nového ventilátora Faro Barcelona, ktorý vám poskytne dizajn, kvalitu a komfort po mnoho rokov. Sme hrdí na našu prácu a oceňujeme príležitosť poskytnúť jeden z najlepších stropných ventilátorov. Je čas začať si užívať váš stropný ventilátor Faro Barcelona!

<< العربية
تهانينا على شراء مروحة فارو برشلونة الجديدة التي ستوفر لك التصميم والجودة والراحة لسنوات عديدة. نحن فخورون بعملنا ونقدر الفرصة لتزويدك بأحد أفضل مراوح السقف المتاحة. لقد حان الوقت لبدء الاستمتاع بمروحة السقف فارو برشلونة.



**Together
we take care
of the planet**

Together we take care of the planet.

This is why we reduce paper consumption. Please refer to the safety, maintenance and warranty instructions at www.faro.es. If you cannot access it, call us at +34 937 723 965 or write to export@faro.es.

Juntos cuidamos el planeta. Por eso reducimos el consumo de papel. Puedes consultar las instrucciones de seguridad, mantenimiento y garantía en www.faro.es. Si no puedes acceder, llámanos al +34 902 165 166 o escríbenos a faro@lorefar.com.

Junts cuidem el planeta. Per això reduïm el consum de paper. Pots consultar les instruccions de seguretat, manteniment i garantia en www.faro.es. Si no hi pots accedir, telefona'ns al +34 902 165 166 o escriu-nos a faro@lorefar.com.

Ensemble, nous prenons soin de la planète. C'est pourquoi nous réduisons la consommation de papier. Veuillez-vous référer aux instructions de sécurité, d'entretien et de garantie sur www.faro.es. Si vous ne pouvez pas y accéder, appelez-nous au +34 937 723 965 ou écrivez à export@faro.es.

Insieme proteggiamo il pianeta. Questo è il motivo per il quale abbiamo ridotto il consumo di carta. Per favore, leggi le istruzioni sulla sicurezza, la manutenzione e la garanzia sul sito www.faro.es. Se non puoi accedere, chiamaci al +34 937 723 965 o scrivi a export@faro.es.

Juntos cuidamos do planeta. É por este motivo que reduzimos o consumo de papel. Consulte as instruções de segurança, manutenção e garantia em www.faro.es. Se não conseguir aceder, ligue para +34 937 723 965 ou escreva para export@faro.es.

Gemeinsam sorgen wir uns um unseren Planeten. Deshalb reduzieren wir den Papierverbrauch. Bitte beachten Sie die Sicherheits-, Wartungs- und Garantiehinweise unter www.faro.es. Wenn Sie nicht darauf zugreifen können, rufen Sie uns unter +34 937 723 965 an oder schreiben Sie an export@faro.es.

We dragen samen zorg voor onze planeet. Daarom verminderen wij het papiergebruik. Raadpleeg de veiligheids-, onderhouds- en garantiehandleiding op www.faro.es. Kan u ze niet raadplegen? Bel ons op +34 937 723 965 of schrijf ons op export@faro.es.

Μαζί φροντίζουμε τον πλανήτη. Για αυτόν τον λόγο μειώνουμε την κατανάλωση χαρτιού. Παρακαλούμε, ανατρέξτε στις οδηγίες ασφαλείας, συντήρησης και εγγύησης στην ιστοσελίδα www.faro.es. Αν δεν μπορείτε να αποκτήσετε πρόσβαση, τηλεφωνήστε μας στο +34 937 723 965 ή γράψτε μας στο export@faro.es.

Вместе мы заботимся о планете. Вот почему мы сокращаем потребление бумаги. Пожалуйста, обратитесь к инструкциям по безопасности, техническому обслуживанию и гарантии на сайте www.faro.es. Если вы не можете получить к нему доступ, позвоните нам по телефону +34 937 723 965 или напишите на export@faro.es.

Společně pečujeme o planetu. Proto omezujeme spotřebu papíru. Přečtěte si, prosím, pokyny týkající se bezpečnosti, údržby a záruky na www.faro.es. Pokud na stránky nemáte přístup, zavolejte nám na tel. +34 937 723 965 nebo napište na export@faro.es.

Razem dbamy o planetę. Dlatego zmniejszamy zużycie papieru. Proszę zapoznać się z instrukcjami bezpieczeństwa, konserwacji i gwarancji na www.faro.es. Jeśli nie możesz uzyskać do niego dostępu, zadzwoń do nas pod numer +34 937 723 965 lub napisz na adres export@faro.es.

Зедно ние се грижим планетата. Ето защо намаляваме консумацията на хартия. Моля, направете справка с инструкциите за безопасност, поддръжка и гаранция на www.faro.es. Ако нямате достъп до сайта, обадете ни се на +34 937 723 965 или пишете на export@faro.es.

Spoločne sme sa postarali o tejto planéte. To je dôvod, prečo sme znížili spotrebu papiera. Pozri pokyny k bezpečnosti, údržby a záruky na www.faro.es. Ak nemôžete prístupovať, zavolajte na telefónne číslo +34 937 723 965 alebo pište n export@faro.es.

معا نعتني بالكوكب.

هذا هو السبب في تقليل استهلاك الورق.

يرجى الرجوع إلى تعليمات السلامة

والصيانة والضمان على www.faro.es

إذا لم تتمكن من الولوج إليه، اتصل بنا

على +34 937 723 965 أو اكتب رسالة

إلى export@faro.es



> **ESPAÑOL:** El manual de contiene las instrucciones completas para instalar y operar con su ventilador de forma segura.

Recuerde apretar firmemente todos los tornillos y hacer todas las conexiones correctamente.

> **CATALÀ:** Els manuals contenen les instruccions completes per instal·lar i operar amb el seu ventilador de forma segura.

Recordi estrènyer fermament tots els cargols i fer totes les connexions correctament.

> **ENGLISH:** The manuals contain the complete instructions for installing and operating with your fan safely. Remember to tighten all screws firmly and make all connections correctly

> **FRANÇAIS:** Le manuel d'utilisation contient les instructions complètes pour installer et utiliser votre ventilateur en toute sécurité. N'oubliez pas de serrer toutes les vis fermement et de faire toutes les connexions correctement

> **ITALIANO:** Il manuale operativo contiene le istruzioni complete per installare ed utilizzare il suo ventilatore in totale sicurezza. Ricordi di avvitare bene tutti i bulloni e realizzare tutte le connessioni nella maniera corretta.

> **PORTUGÊS:** O manual de operação contém as instruções completas para instalação e operação com o seu ventilador com segurança. Lembre-se de apertar firmemente todos os parafusos e fazer todas as conexões corretamente.

> **DEUTSCH:** Die Betriebsanleitung enthält vollständige Anweisungen für die sichere Installation und den sicheren Betrieb Ihres Ventilators. Denken Sie daran, alle Schrauben fest anzuziehen und alle Verbindungen korrekt herzustellen.

> **NEDERLANDS:** De gebruikshandleiding bevat de volledige instructies voor de installatie en de veilige bediening van uw ventilator. Vergeet niet om alle schroeven stevig vast te draaien, en alle verbinding correct aan te sluiten.

> **ΕΛΛΗΝΙΚΗ:** Το εγχειρίδιο λειτουργίας περιέχει τις πλήρεις οδηγίες για την εγκατάσταση και λειτουργία με τον ανεμιστήρα σας με ασφάλεια. Θυμηθείτε να σφίξετε καλά όλες τις βίδες και να κάνετε σωστά όλη τη συνδεσμολογία.

> **РУССКИЙ:** Руководство по эксплуатации содержит полные инструкции по установке и безопасному использованию вашего вентилятора. Не забудьте крепко затянуть все винты и правильно установить все соединения.

> **ČESKY:** Provozní příručka obsahuje kompletní pokyny pro instalaci a bezpečný provoz vašeho ventilátoru. Nezapomeňte pevně dotáhnout všechny šrouby a vše správně připojit!

> **POLSKI:** Instrukcja obsługi zawiera kompletnie wskazówki dotyczące bezpiecznego instalowania i obsługi wentylatora. Pamiętaj, aby mocno dokręcić wszystkie śruby i prawidłowo wykonać wszystkie połączenia!

> **БЪЛГАРСКИ:** Ръководството за експлоатация съдържа пълните инструкции за безопасно монтиране и работа с вашия вентилатор. Не забравяйте да затегнете здраво всички винтове и да свържете правилно всички връзки.

> **SLOVENČINA:** Návod na obsluhu obsahuje úplné pokyny na inštaláciu a bezpečnú prevádzku s ventilátorom. Nezabudnite pevne utiahnuť všetky skrutky a urobiť všetky pripojenia správne.

<< العربية
يحتوي الدليل على التعليمات الكاملة لتثبيت
المروحة وتشغيلها بأمان. تذكر أن تشد بقوة
جميع البراغي والقيام بجميع التوصيلات بشكل
صحيح.

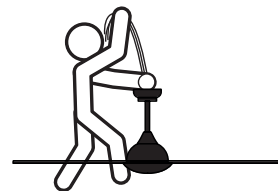
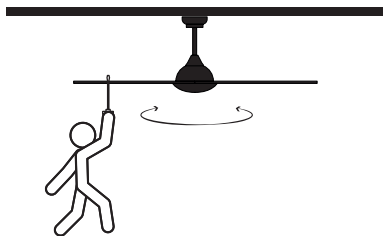
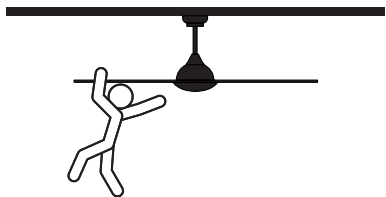
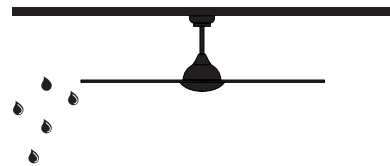
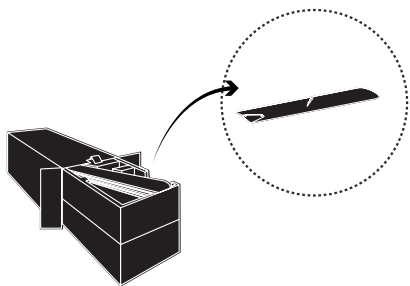

technical specifications

speeds	A	W	RPM	CFM	m ³ min
I - low	0.08	6	54		
II	0.11	9	67		
III	0.16	15	79		
IV	0.27	28	98		
V - High	0.39	44	112	12159	344.4

power	
V	220-240
Hz	50 - 60

sizes mm/inch	
A	440 / 17.32"
A1	425 / 16.73"
B	∅148 / 5,82"
C	∅2088 / 82"
D	930 / 36,61"

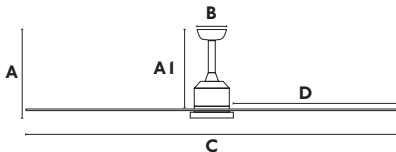

weight	
kg	11,20
lb	24,64



Cies

motor	
material	Steel
finished	shiny white

blades	
material	ABS
finished	white



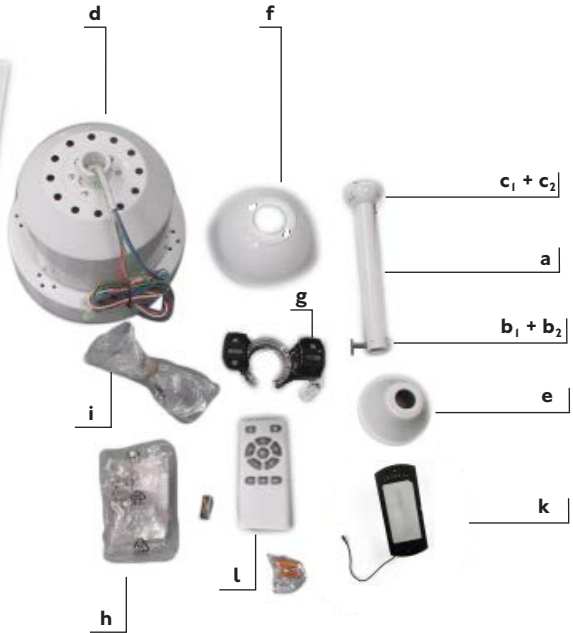
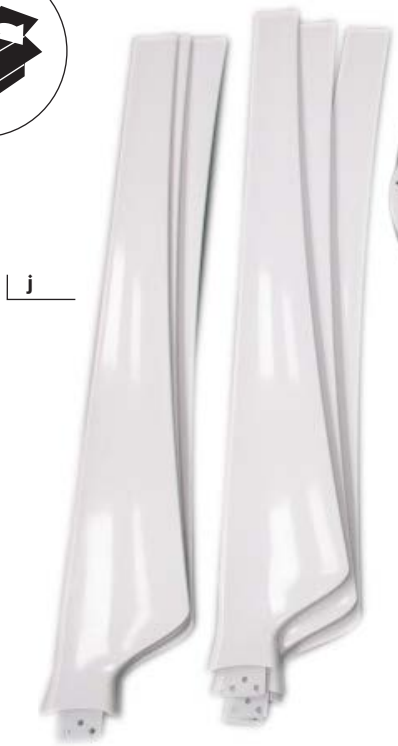
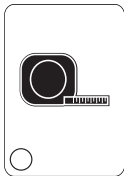
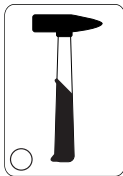
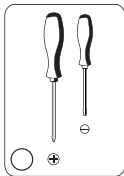
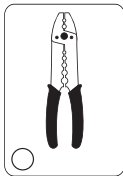
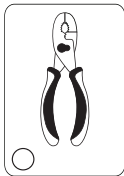

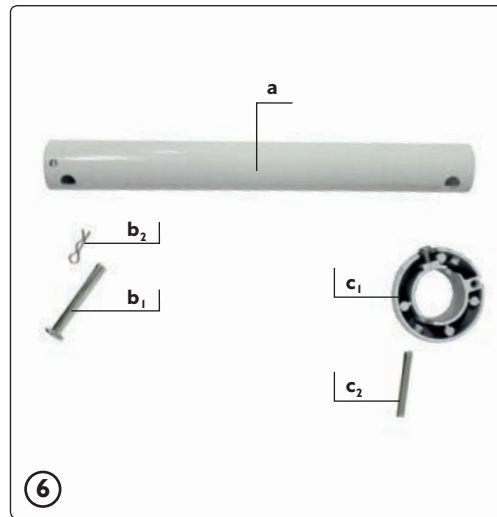
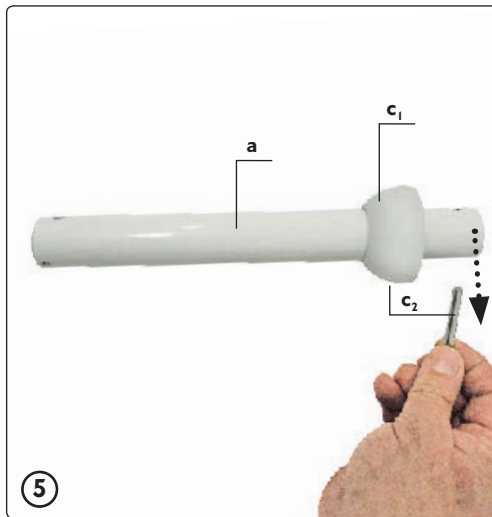
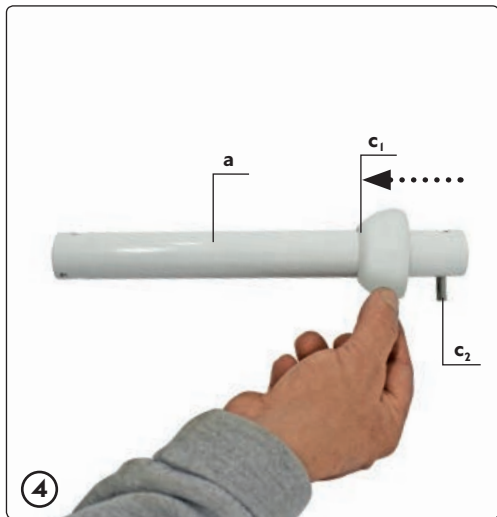
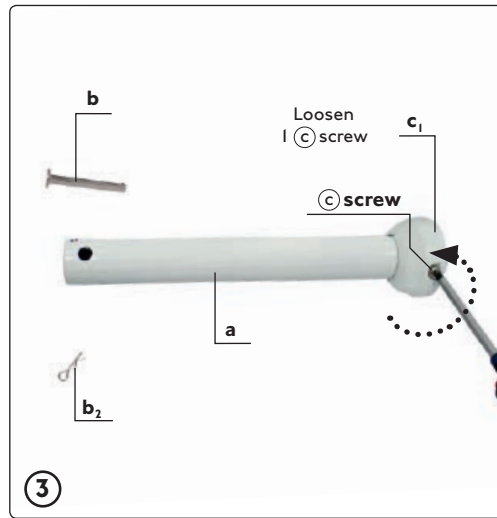
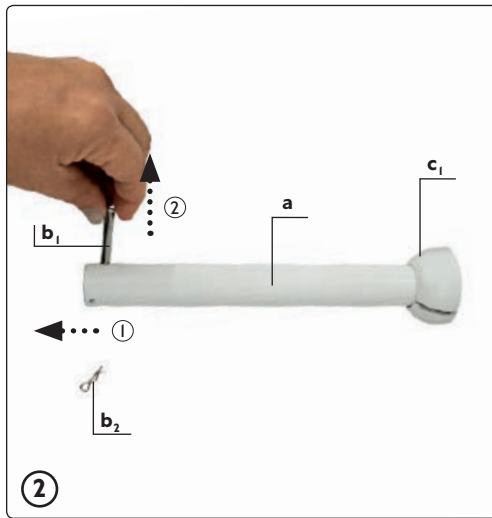
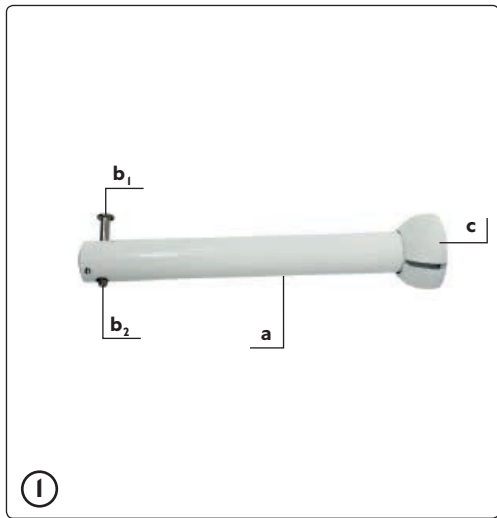

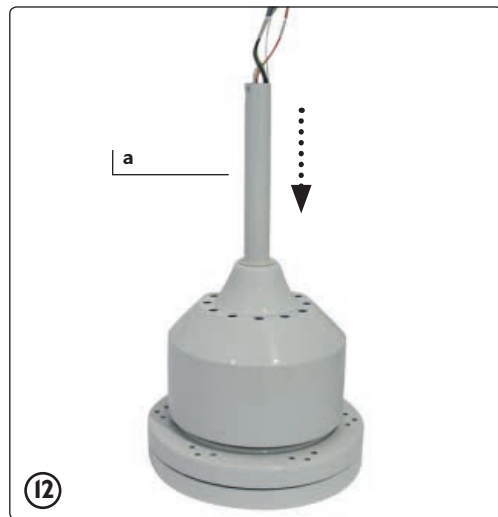
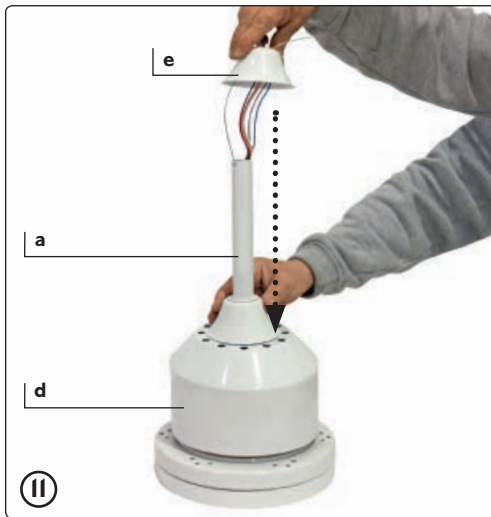
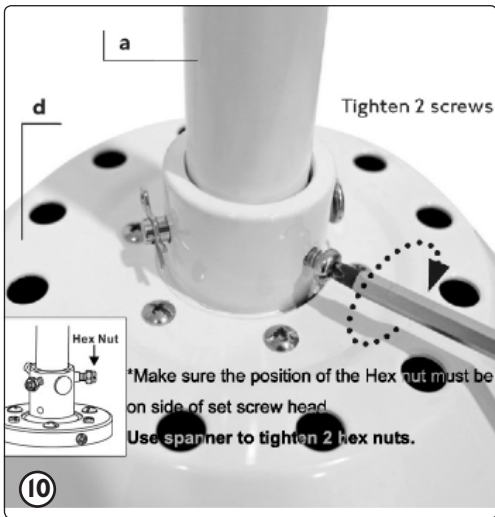
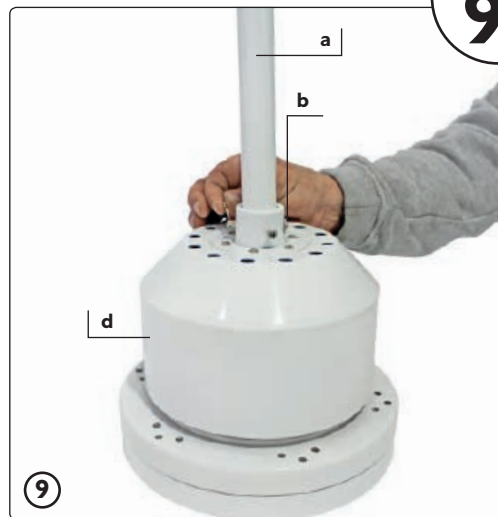
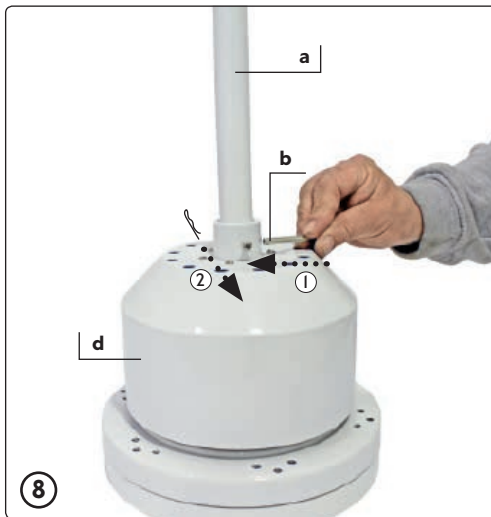
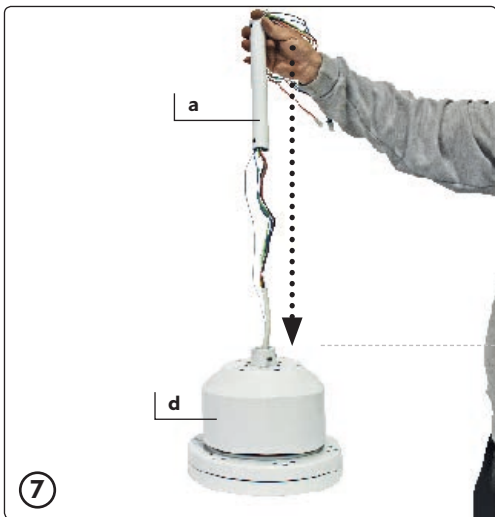

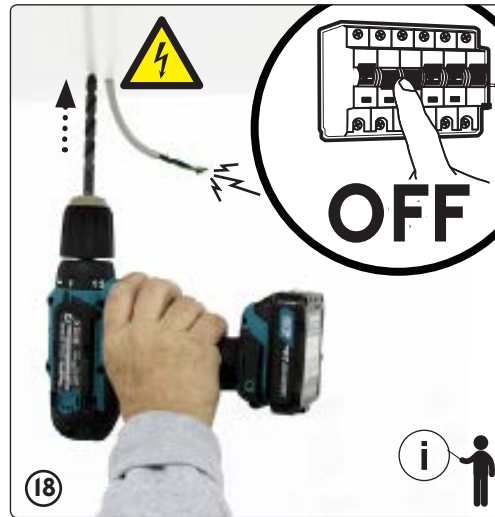
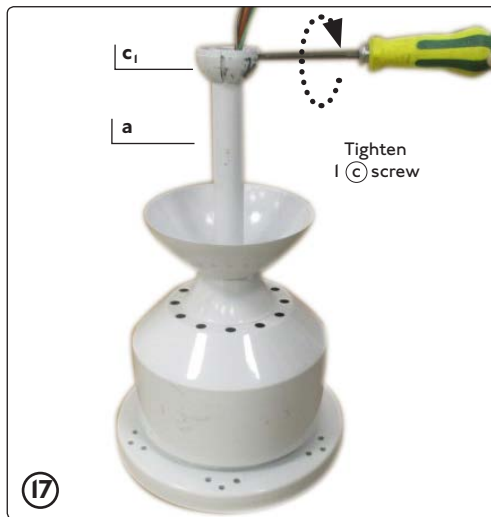
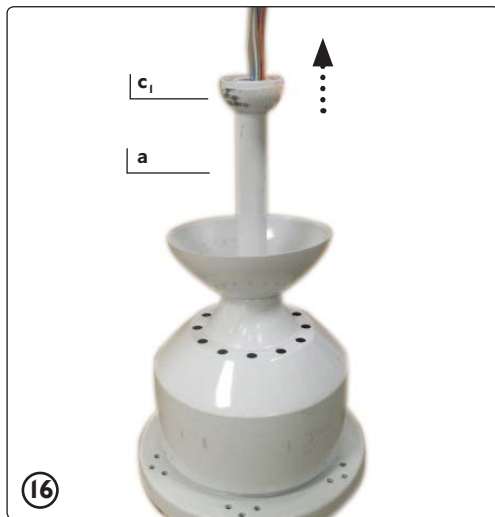
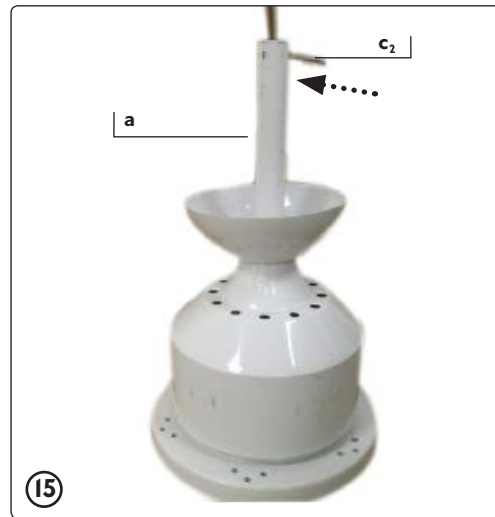
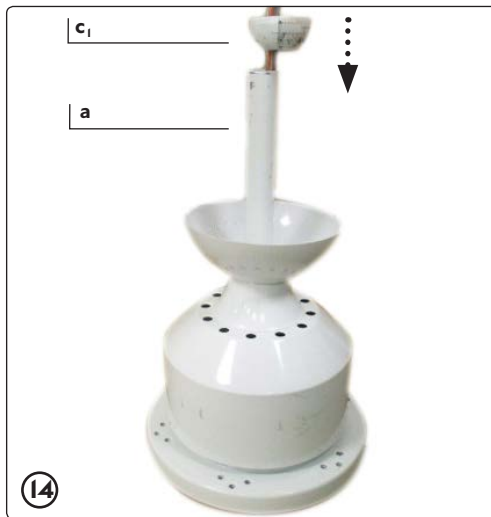
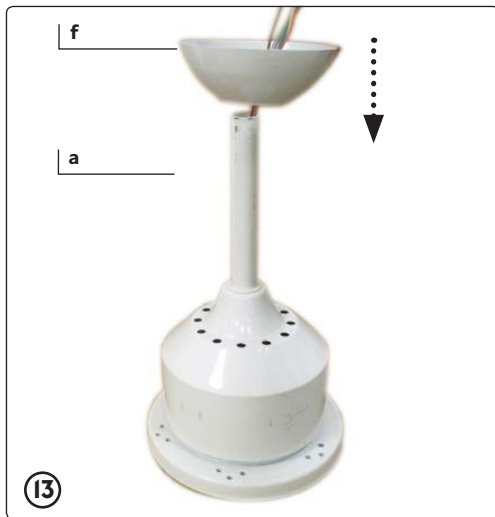

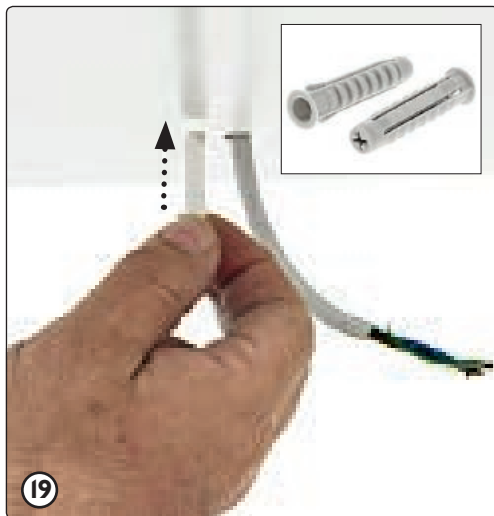

19

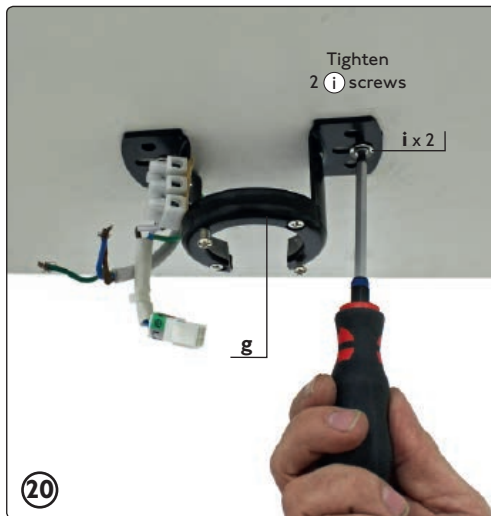

20

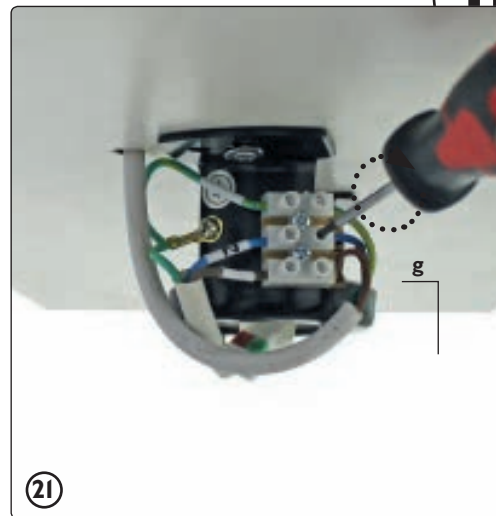

21

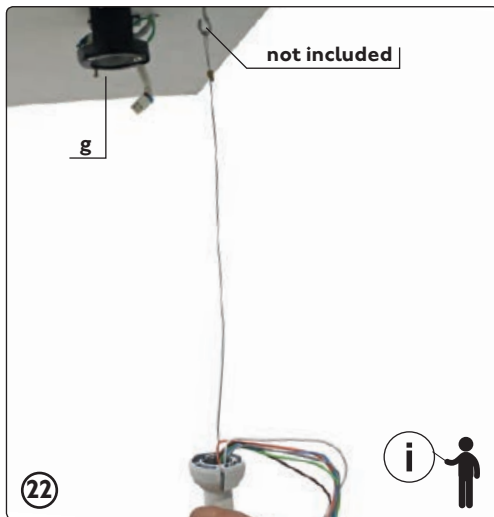

22

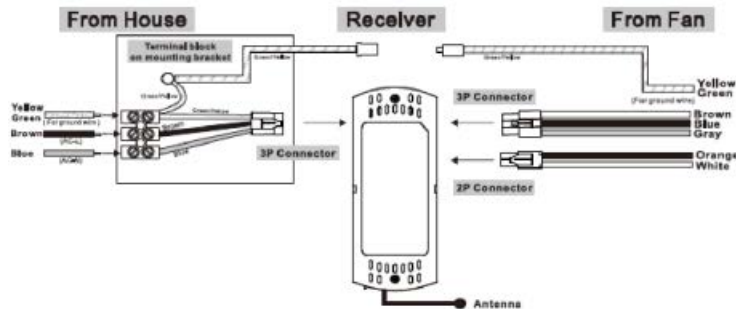

*** Special note: All Green grounding wires, from Hanger ball/Mounting bracket/Receiver, must be well attached to House Ground/Earth to prevent flickering of LED. ***

L: marrón, marró, brown, marron, marrone, castanho, braun, bruin, кафэ, коричневый, hnědá, brązowy, niebieski, син, modrý, кафяв, hnedý

N: azul, blau, blue, bleu, blu, azul, blau, blauw, μπλε, синий, modrá, niebieski, син, modrý

⊕: amarillo-verde, groc-verd, ye-

low-green, jaune-vert, giallo-verde, verde-amarelo, gelb-grün, gell-groen, кίτρινο-πράσινο, желто-зеленый, žltozelená, жółто-zielony, жълто-зелен, žltozelená

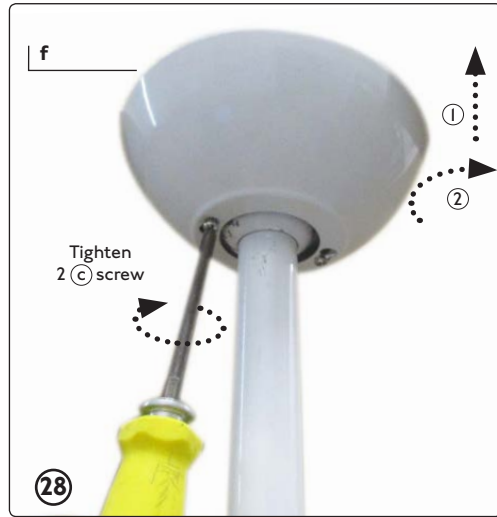
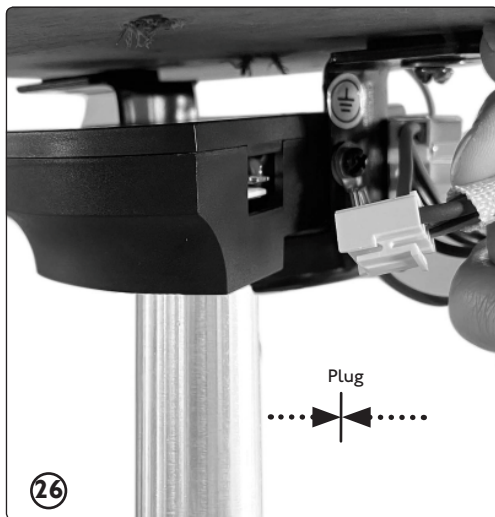
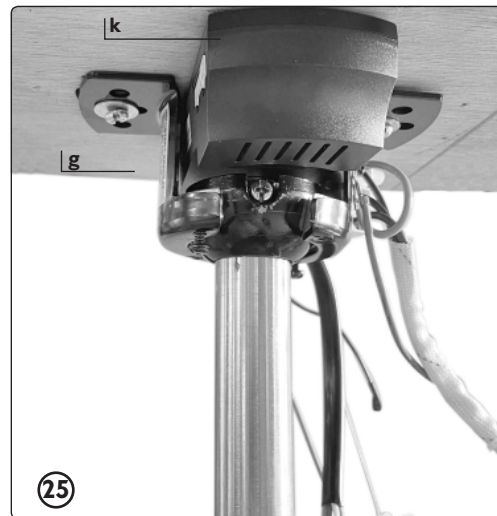
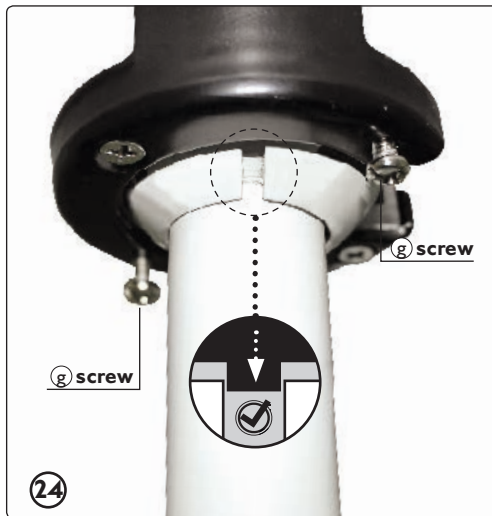
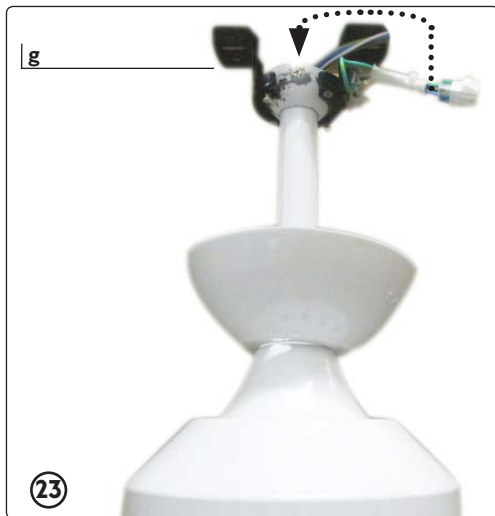

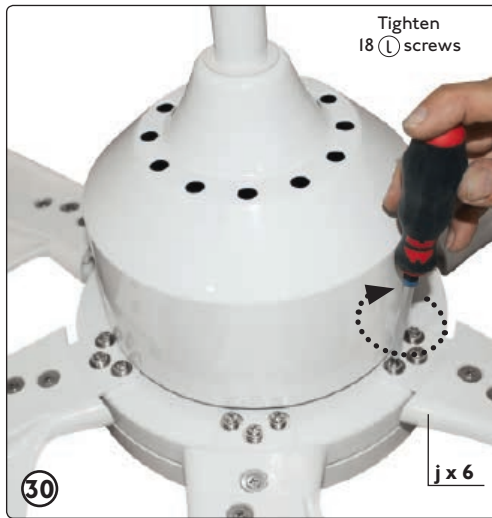

Pre-synchronized remote control

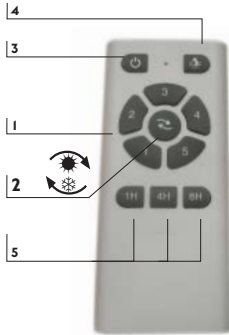

ESPAÑOL

- 1- Velocidad
- 2- Función inversa
- 3- Encendido y apagado del ventilador
- 4- Luz (kit de luz ref. 33513 opcional. Ver www.faro.es)
- 5- Programable: Funcionará durante 1h, 4h, 8h

CATALÀ

- 1- Velocitat
- 2- Funció inversa
- 3- Encen i apaga el ventilador
- 4- Llum (kit de llum ref. 33513 opcional. Veure www.faro.es)
- 5- Programable: Funcionará durant 1h, 4h, 8h

ENGLISH

- 1- Fan speed
- 2- Reverse function
- 3- On off for fan
- 4- Light (light kit ref. 33513 is optional. See www.faro.es)
- 5- With Programmer: It will works for 1h, 4h, 8h

FRANÇAIS

- 1- Vitesses
- 2- Interrupteur a sens inverse pour changer la direction du tour du ventilateur
- 3- On/off ventilateur
- 4- Lumiere (kit d'éclairage réf. 33513 est facultatif. www.faro.es)
- 5- Avec Programmeur: Fonctionne pendant 1h, 4h, 8h

ITALIANO

- 1- Velocità
- 2- Senso di rotazione del ventilatore, in avanti o indietro.
- 3- On/Off ventola
- 4- Luce (kit luce ref. 33513 è opzionale. www.faro.es)
- 5- Programmabile: Finzione per 1, 4, 8, 8h

PORTUGÊS

- 1- Velocidades da ventoinha
- 2- Controla a direcção de rotação, para a frente ou para trás
- 3- Começando marcha e desemprego do ventoinha
- 4- Luz (kit de luz ref. 33513 é opcional. www.faro.es)
- 5- Programável: Funciona por 1h, 4h, 8h

NEDERLANDS

- 1- Snelheid van de ventilator
- 2- Inverse functie
- 3- Onn/off Verlichting
- 4- Verlichtingsset (light kit ref. 33513 is optioneel. www.faro.es)
- 5- Programmeerbare: Werkt voor 1t, 4t, 8t

DEUTSCH

- 1- Ventilatorgeschwindigkeit
- 2- Umkehrfunktion
- 3- On/off ventilator
- 4- Verlichtingsset (Licht Kit Ref. 33513 ist optional. www.faro.es)
- 5- Programmierbar: Arbeitet für 1s, 4s, 8s

ΕΛΛΗΝΙΚΗ

- 1- Ταχύτητα
- 2- Αντίστροφη συνάρτηση
- 3- Ένατος και εκτός του ανεμιστήρα
- 4- Φωτισμού (light kit ref. 33513 είναι προαιρετικό. www.faro.es)
- 5- Προγραμματιζόμενη: Λειτουργεί για 1, 4, 8 ώρες

РУССКИЙ

- 1- Скорость
- 2- Положение переключателя скоростей на период жаркой или холодной погоды
- 3- Позиция выключения вентилятора
- 4- Освещения press (легкий комплект иск. 33513 необязательно. www.faro.es)
- 5- Программируемые: Работает 1, 4, 8 часов

ČESKY

- 1- Otáčky ventilátoru
- 2- Inverzní funkce
- 3- On/off ventilátoru
- 4- Osvětlení (světelná sada ref. 33513 je volitelná. www.faro.es)
- 5- Programmable: Pracuje na 1, 4, 8 hodin

POLSK

- 1- Prędkości
- 2- Punkcja odwrotła
- 3- On/off wentylatora
- 4- Oświetlenia (zestaw światła ref. 33513 jest opcjonalny. www.faro.es)
- 5- Programowanie: Działa przez 1, 4, 8 godzin

БЪЛГАРСКИ:

- 1- Скорост
- 2- Обратна функция
- 3- On/off вентилатора
- 4- Осветление (комплект светлина ref. 33513 не е задължително. www.faro.es)
- 5- Программуем: Работи за 1, 4, 8 часа

SLOVENČINA

- 1- Rýchlost
- 2- Inverznej funkcie
- 3- On/off ventilátora
- 4- Svitlida (svetelná súprava ref. 33513 je voliteľný. www.faro.es)
- 5- Programovateľný: Pracuje na 1, 4, 8 hodiny

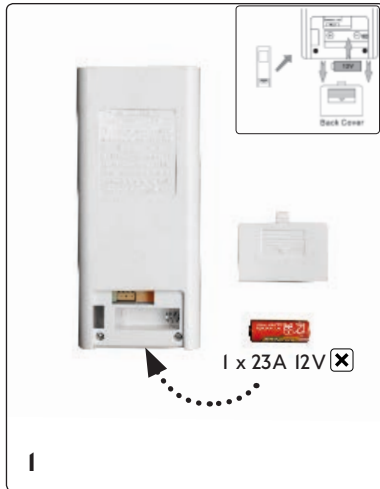

1 x 23A I2V X



?



Fan not sync

If remote control doesn't work, proceed as below:

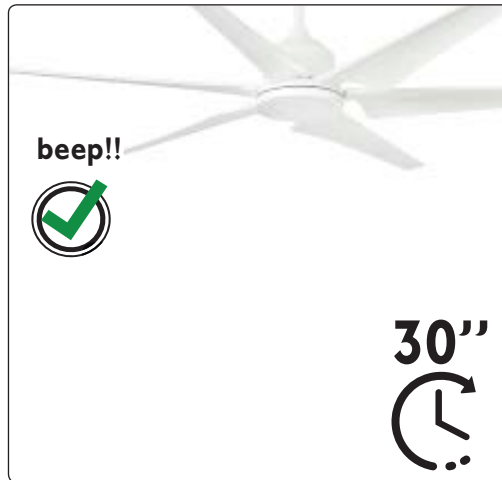
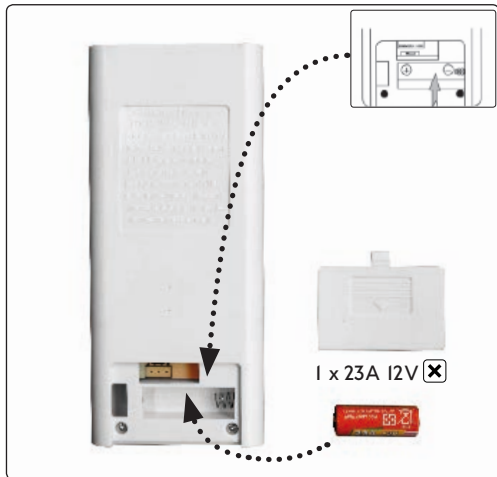



Sync remote controls with 2 or more fans

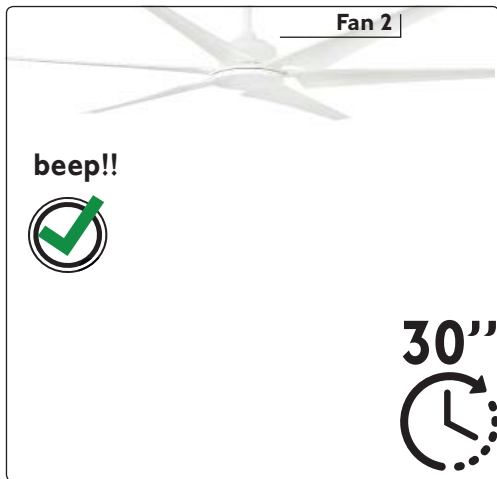
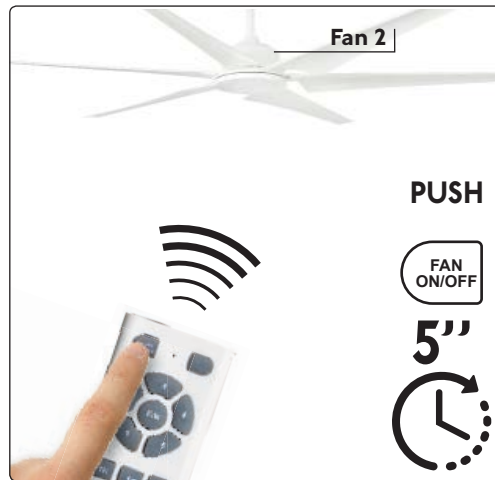
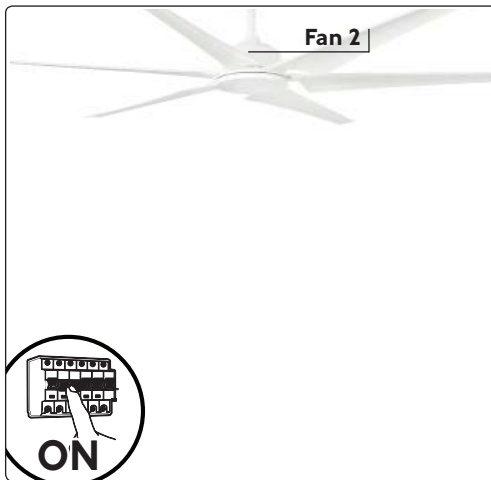
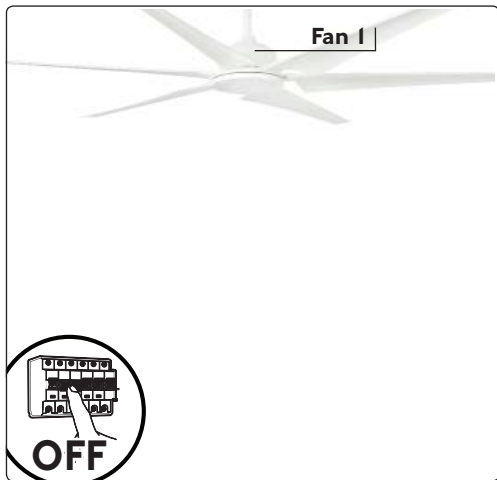

Installation Guide

Ref. 33513

Light Kit for Cies Ceiling Fan









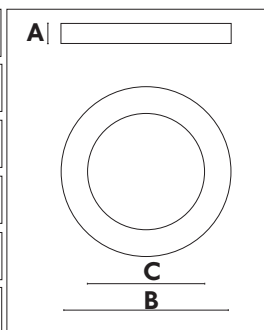





material	ABS + PC
finished	shiny white

power			
V	220-240	Hz	50 - 60

sizes mm/inch	
A	35/1,37"
B	Ø230/9,05"
C	Ø160/6,30"

weight			
kg	0.6	lb	1.32



 SMD LED 18W 3000K, 900lm						
LED G This product contains a light source of energy efficiency class G Este producto contiene una fuente luminosa de la clase eficiencia energética G						
						
					Together we take care of the planet	

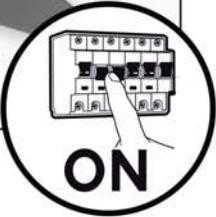
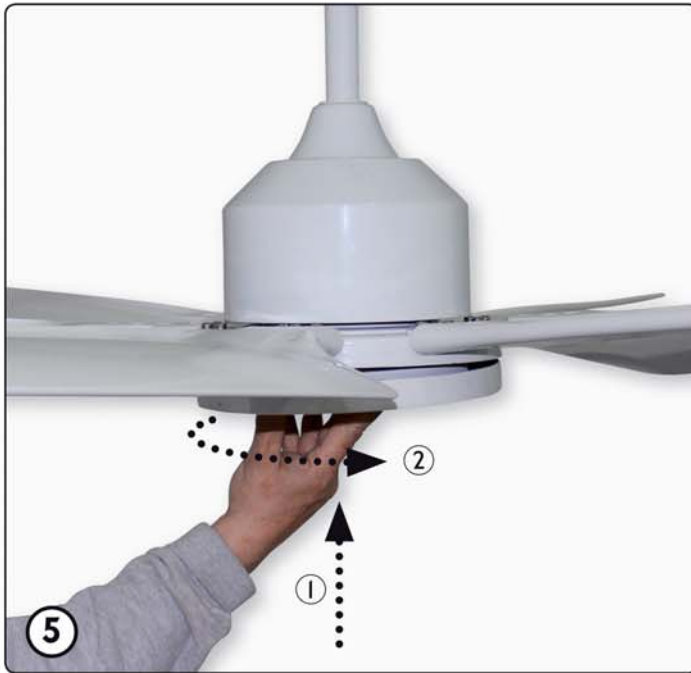
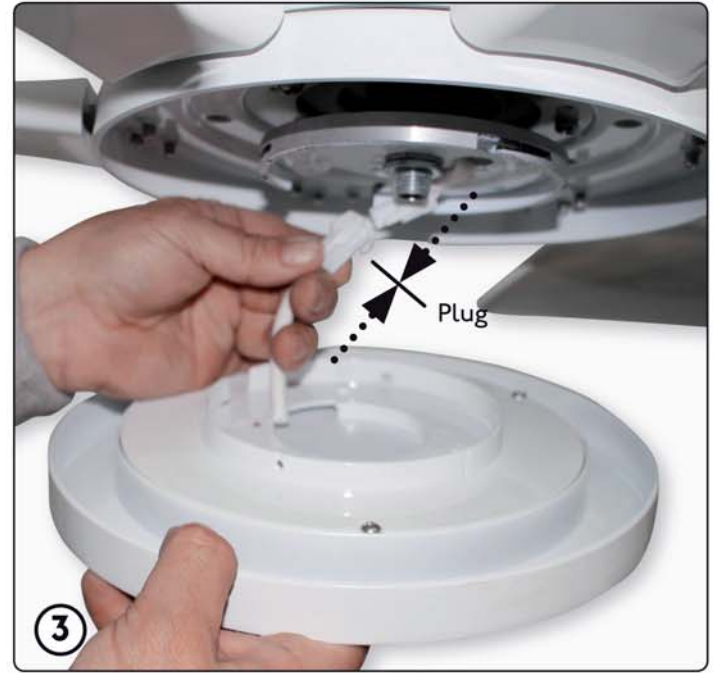
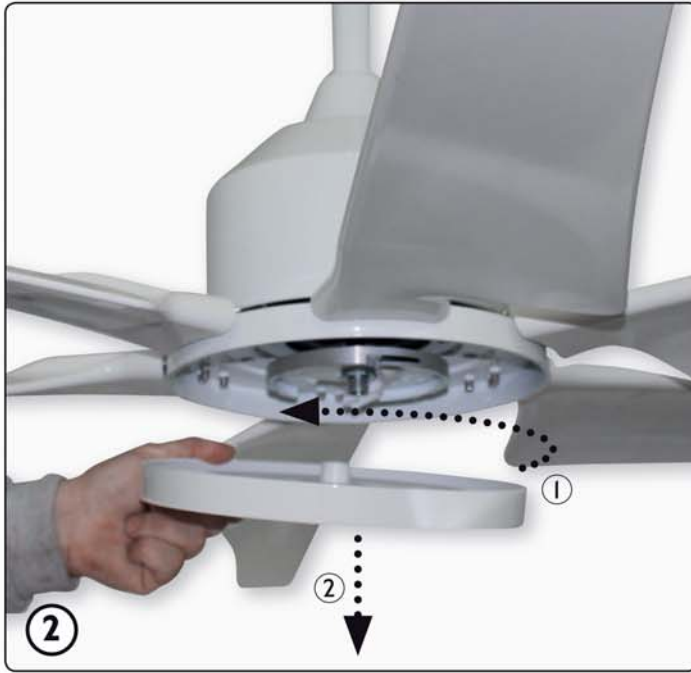
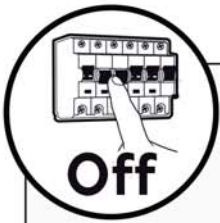

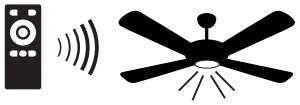

Remote control: light



Light: ON-OFF and Dimmer

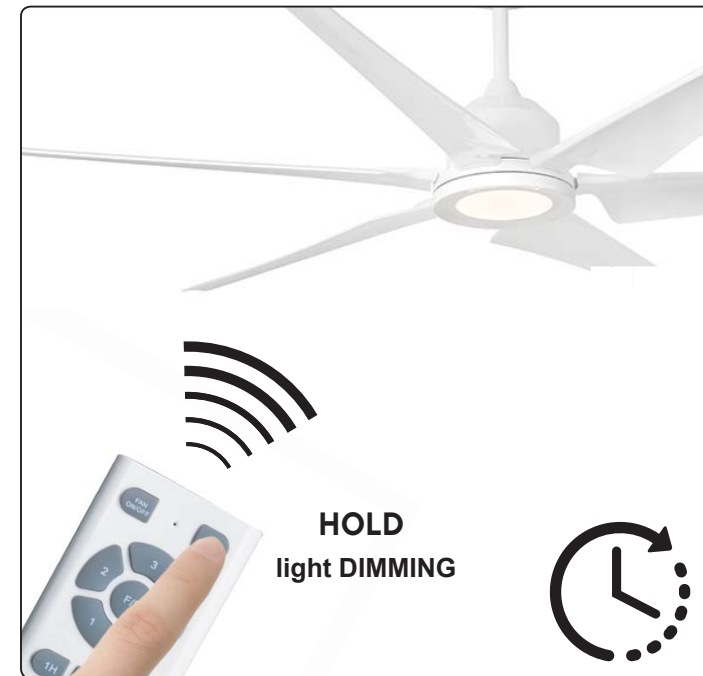
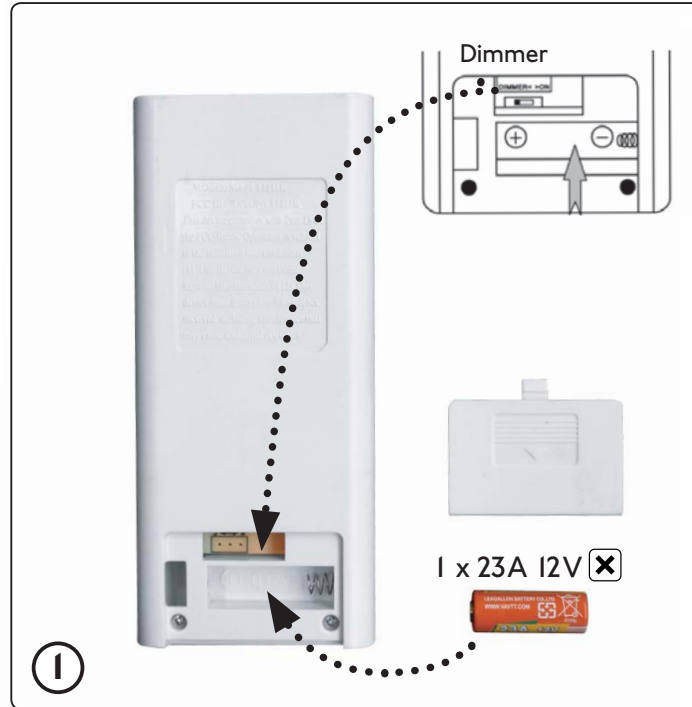

F A R O
B A R C E L O N A

WHERE ARE WE

Calle Dinámica N° 1, Pol. Ind. Santa Rita
08755 Castellbisbal, Barcelona SPAIN

CALL US

Ph +34 918 315 425
Fax +34 937 720 018

DOWNLOAD



farofar@lorefar.com
www.farofar.es